

# WOOD CHIPS



Northwest Indiana Woodworkers Association  
Volume 16, Issue 9 September 2012

## President's Corner

Greetings Woodworkers, What a crazy time it is. One minute its 80 degrees the next minute it's in the 40s. Fall is surely here. It's time to begin making Christmas gifts for friends and finish making Christmas toys for the kids. Keep in mind that the economy is still recovering and the kids need your help. We are still shy on our goal of 1000. Please try to make even a few toys. A smile on a child's face on Christmas morning is what makes the holiday heart beat. We also need names of church and civic organizations to give toys to. Please bring this information to this month's meeting or call Claudia if you can't make the meeting.

Bring the **Christmas Tree Topper** you made for the competition this month. We will have a drawing for those that made a topper and a \$25.00 gift certificate will be awarded. Bring the Christmas tree ornaments you made for the **Christmas Tree Display** to this month's meeting. The Christmas tree will be set up in October at the Welcome Center located at I94 the Kennedy Ave Exit. If you have time to help setup, contact Claudia, for the date and information. Last year we won 2<sup>nd</sup> place. Let's make this year a First Place Year!

The **Picnic** was a great success. I was met at the pavilion by Skip Brazil and Fred Baginski. They were ready to have fun. Skip had most of the tables ready and Fred was firing up the grill. Members arrived ready for fun. Ron Benson brought the ice table tray and the bean bag games. The guys played until the rain fell. The weather was a little testy but for the most part, the weather was fine. There were no bees, could you believe it! The food was wonderful. The ladies out did themselves with the dishes they brought. Door prizes were 5 napkin holders made by Skip Brazil and finished by Duane Bomba. They were a big hit. Bingo was called by Duane Bomba. The members enjoyed their bingo winnings. Everyone had a GREAT time! To everyone that made this outing a success, thank you!

**Art Willing** member and story teller is now in heaven with the Great Carpenter. Art, we miss your stories and your contagious smile. It has been a privilege to know you. We still remember your 2x4 stretcher and your pitch for investors. Yes, you are a great story teller. God bless you and your family. You are missed. Please keep Helen, his wife in your prayers.

You never know what life has in store for us. Enjoy each other and have fun! God Bless all of you.

You're President,  
Marcia Lichnerowicz

**September's Speaker** will be Frank Schmidt. The program is Woodworking with the Blind. Frank has been a shop teacher in Florida. It is an incredible program. You won't want to miss this!

**Carving SIG** will meet at 6pm before the meeting. Bring your carving stuff. This is a fun time to make woodchips the old fashion way, no power tools ;)

### **SHOW AND TELL**



Bob Rinearson



John Hunter



Max Hernick



Dick Sader



Ron Benson



Sandy Rinker



Bob Miller





Marcia Lichnerowicz



Phil Malavolta



Mick King



Ron Benson

## **TOYS**

November is drawing near and you will need to give Claudia & Skip Brazil ([claudia35@frontier.com](mailto:claudia35@frontier.com)) (219-926-5966) the names of the organizations that you want to receive the toys. Please submit as soon as possible. We will be passing a sign up sheet around in September and October.

We have not yet reached our goal of 1,000 toys (we are now at 823). Please try to do a few toys. The kids really appreciate them.

## **TREE TOPPER CONTEST**

You should bring your "tree toppers" for the Christmas Tree we will be decorating at the end of November. We are asking all who wish to participate to bring a Christmas topper that is between 8" and 10" tall. All those participating will have a chance to win a \$25 gift certificate. Also, please note that there are only 2 meetings left to bring in any Christmas ornaments you might have. We need them no later than the October meeting.

## **ITEMS FOR SALE**

**If you have any wood working related items that you wish to sell through the newsletter please contact Lalo Gonzalez [LaLogon@sbcglobal.net](mailto:LaLogon@sbcglobal.net) or John Hunter [john.b.hunter@frontier.com](mailto:john.b.hunter@frontier.com) Include a description and the price you are selling them for, also how you may be contacted.**

**If you are looking for a tool that another member would like to sell you can place a wanted ad in the newsletter, just contact John Hunter at [john.b.hunter@frontier.com](mailto:john.b.hunter@frontier.com)**

## **CALENDAR OF EVENTS**

**2012**

September 27<sup>th</sup> Membership Meeting at Hidden Lake 7:00 PM Frank Schmidt  
Woodworking for the blind  
October 1<sup>st</sup> Executive Board Meeting at Portage Library 7 PM  
October 16<sup>th</sup> Committees Meeting at Marcie's home 7:00 PM  
October 25<sup>th</sup> Membership Meeting at Hidden Lake 7:00 PM Chuck Norrman bird Feeders  
November 20<sup>th</sup> Committees Meeting at Hidden Marcie's home 7:00 PM  
November 15<sup>th</sup> Membership Meeting at Hidden Lake 7:00 PM Toy Program  
December 18<sup>th</sup> Committees Meeting at Marcie's home 7:00 PM  
December 20<sup>th</sup> Membership Meeting at Hidden Lake 7:00 PM Christmas Party,  
Installation and Awards

**TIP: Freeze Candle Wax Drips to Remove**

The easy way to remove candle wax that has dripped onto a finished surface is to freeze it by holding an ice cube on it for about 10 seconds. Once frozen, the wax is easy to pick off the finish without causing any damage.

If a little wax residue remains and you can't pick it off, dissolve it with mineral spirits (paint thinner) or a clear furniture polish and wipe away the residue with a cloth.

Be aware that red candle wax can stain a light finish. There's no easy way to remove this stain, but it will fade in time.

**TIP: Soften Sharp Edges**

It's very important that you soften all machined or hand-planed wood edges before applying any film-building finish. The finish will peel away from sharp edges (as is shown in the example) if they aren't rounded over a little.

It's also a good idea to soften edges when using non-film-building oil finishes. Sharp edges dent easier than softened edges.

You can easily remove the sharpness from edges with several light passes using medium-grit sandpaper.

**TIP: Oil and Spontaneous Combustion**

Drying oils, especially linseed oil, are the only finishing materials that spontaneously combust. Solvents don't spontaneously combust, paint strippers (including paint or finish residue) don't spontaneously combust, and no type of varnish spontaneously combusts. It's not totally clear whether 100% tung oil can spontaneously combust, so treat it like it does.

As linseed oil dries, it generates heat as a byproduct. If you wad up linseed-oil rags or pile them on top of each other, the heat generated in the middle can't dissipate. It builds up until it reaches the flash point of the cloth and it bursts into flame.

The easy and sure way to protect yourself if you use any product that contains linseed oil, including Danish Oil and all oil-based stains and glazes, is to hang your

rags over the edge of a trash can or similar object or spread the rags out on the floor until they dry. Once dry, you can safely throw the rags in the trash. Dried oil on rags is no different than a dried oil finish or stain on a piece of wood.

If you choose to submerge oily rags in water, then treat them as described above when you take them out. They can still spontaneously combust after the water dries out.

## Clip-On Lamp Holder



I like the extra light that a clip-on lamp gives when I work. The problem is there never seems to be a convenient place to attach one.

To solve this problem, I devised a holder for my shop that can be placed almost anywhere. This holder allows the lamp clip to grip securely so I can have constant and stable light at all times.

The holder is made of  $\frac{3}{4}$ " plywood. A dado in the mounting plate captures a small shelf, as you can see in the photo.

The clip part of the lamp tightly grips the shelf. A pair of dowels in the shelf fit inside the clip bends to prevent the lamp from sliding off the holder when the light position is adjusted.

Good Woodworking,

Phil Huber  
Online Editor, *ShopNotes*

# Drill Press Inserts

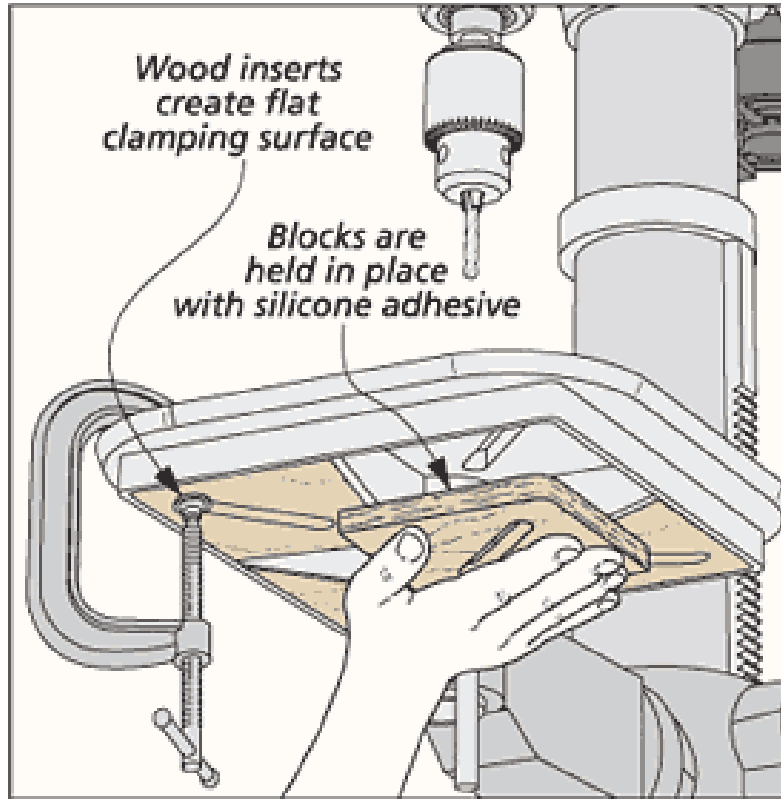

As any drill press user knows, trying to clamp a workpiece directly to the cast iron table can be trying. The reinforcing ribs on the underside of the table can sometimes make positioning and tightening a clamp nearly impossible. After struggling with this problem for far too long, I resolved to solve it.

As you can see in the drawing, I simply cut plywood inserts to fill the spaces between the ribs and provide a flat, solid clamping surface on the underside of the table. I cut slots in the inserts to match the slots in the table so I can still make use of this option. Then the inserts are just stuck in place with silicone adhesive.

Now clamping a workpiece to the table is quick and effortless. And my only regret is not having made this modification a lot sooner.

Good Woodworking,

Ted Raife  
Online Editor, *Woodsmith*