

WOOD CHIPS



Northwest Indiana Woodworkers Association

Volume 27, Issue 10 October 2022

President's Rambling's

Greetings Fellow Woodworkers, Hello everyone, **October meeting** is here and we are bringing Brat Fest back! The Menu will be brats, buns, chips, and kraut. Beverage of choice can be obtained in the social quarters. Jon Robins has volunteered to prepare and cook the brats.

.NOMINATING COMMITTEE: November Elections is here. Here is your chance to become an executive board member for 2023! At the October meeting you can submit your name for the elections in November, consider running for an office!

Message from Santa: The Toy Program is nearing its deadline (November 17th meeting). Time to start putting the finishing touches on the toys for the needy children. Also, we need the names of the Charitable organizations with contacts and address of the organization you would like to see get these items. It will be your responsibility to get the items delivered to your organization(s). You can submit the names of organizations at our next meeting or email them to John Hunter at john.b.hunter@frontier.com. November's meeting is when these toys are passed out and time is running short. We will need some extra boxes and or bags to package up the toys to go to their destinations. Please help where you can and thanks to all members who have and are helping make a merrier Christmas for some needy children.

Christmas Party is coming up on December 15th, 2022 at **6:00 PM** (a week before and an hour earlier than our normal meeting) at 6 PM. A sign up sheet for our members and their guest will be at the October meeting. The dinner will be buffet style with the club providing the meat and drinks. Members are asked to bring a dish and some handmade presents to share with the ladies. We always have wonderful selection of foods. A sign up sheet will be available at the next meeting for the Christmas gifts

Educational Raffle Tickets are still available. Drawing is held at the November meeting.

NOTE TIME AND DATE changes for the last two months of the year!
November 17th at 7 PM general meeting date and time.
December 15th at 6 PM general meeting date and time.

Enjoy this weather and Don't let your tools rust!

Your President, Kevin Sturgeon

SHOW AND TELL



John Fluck



Steve Smith



Bill Schoech

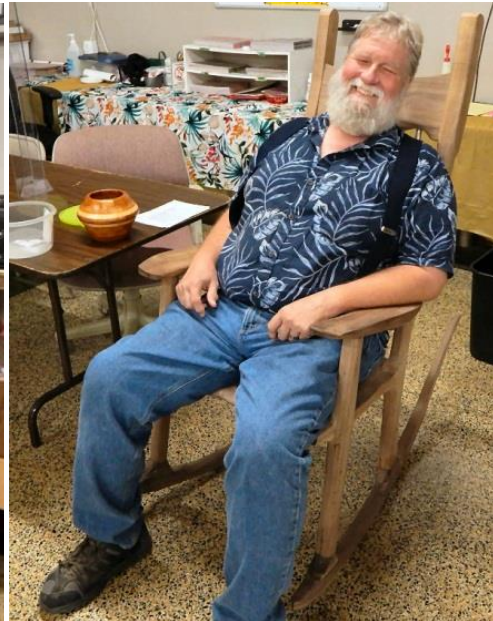

Kevin Sturgeon



James Krone



Dick Sader



Dick Sader

TRACTOR SHOW







ITEMS FOR SALE

If you have any wood working related items that you wish to sell through the newsletter please contact John Hunter john.b.hunter@frontier.com Include a description and the price you are selling them for, also how you may be contacted.

If you are looking for a tool that another member would like to sell you can place a wanted ad in the newsletter, just contact John Hunter at john.b.hunter@frontier.com

2022

October 27th Membership Meeting at Moose Lodge, 143 South Hobart Road, Hobart IN
7:00 PM

November 9th Committees Meeting at Moose Lodge, 143 South Hobart Road, Hobart IN
7:00 PM

November 17th Membership Meeting at Moose Lodge, 143 South Hobart Road, Hobart
IN

7:00 PM Toy Program

December 7th Committees Meeting at Moose Lodge, 143 South Hobart Road, Hobart IN

7:00 PM

December 15th Membership Meeting at Moose Lodge, 143 South Hobart Road, Hobart IN

6:00 PM Christmas Party, Installation and Awards

Woodsmith Tips

Small Parts Clamp

Cutting small parts on the table saw doesn't always involve making a lot of repetitive cuts or identical pieces. Often all I need to do is cut or trim one or two short pieces to length. Or possibly cut several small pieces to size that are each a little different. For a long time, I struggled with making these crosscuts cleanly and accurately without losing my fingers. The solution turned out to be the simple clamping jig you see at use in the photo at right.

This small parts clamp attaches to the miter gauge of the table saw. It holds the workpiece firmly between the two jaws so all I have to worry about is sliding the miter gauge past the blade.

Building the Clamp. As you can see in the drawings below, the construction is pretty simple. Basically, the clamp consists of a back jaw, an adjustable front jaw, and a slotted spreader that connects them.

You start by cutting the front and back jaw to identical size from $\frac{3}{4}$ "-thick hardwood. Then you drill matching holes at the "blade" end of the jaws to hold the carriage bolt that tightens the clamp.

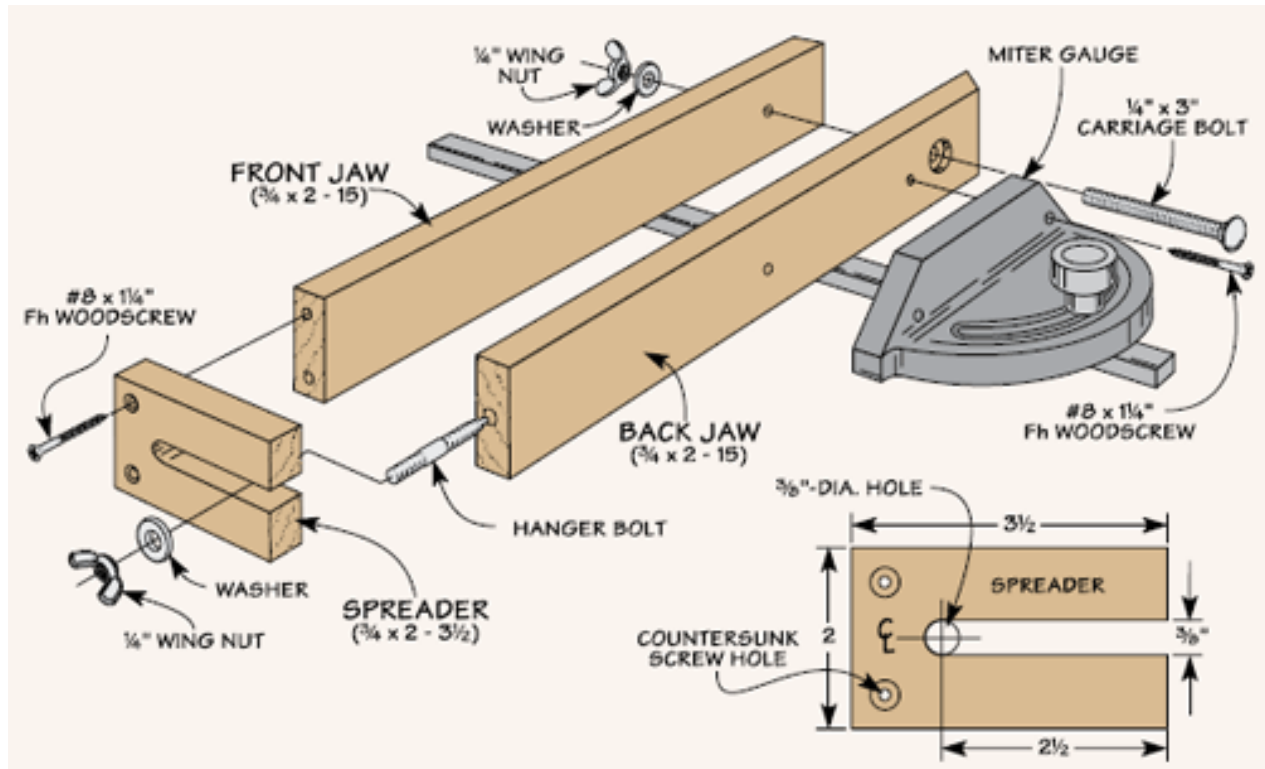
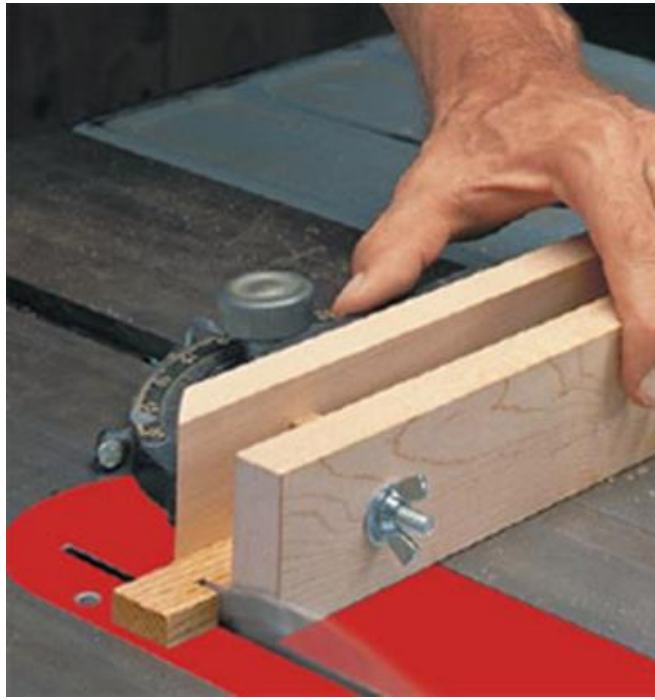

Once the slot is cut in the spreader, you can screw it to the opposite end of the front jaw. The slot fits over a hanger bolt installed in the end of the back jaw. Both ends of the clamp are tightened down with wing nuts and washers.

Using It. Putting the clamp to use doesn't need much explanation. First, you adjust the jaws to loosely fit the workpiece. Then line up your cut mark on the workpiece with the

blade and tighten the wing nuts. Making the cuts is just a matter of sliding the miter gauge past the saw blade.

Good woodworking, Phil Huber

Edge Trimming Guide



Trimming the solid-wood edging glued to a plywood panel has always been one of my least favorite tasks. So I'm always trying to find a quick, easy, and accurate way to get it done. The router table setup you see in the photo at right just might be the final answer.

The key to the operation is a tall auxiliary fence that supports the plywood panel. It's simply attached to the router table fence with double-sided tape. But now look close and you'll see that the fence is suspended above the table top so that the oversize edging on the panel can pass beneath it (see drawings). Finally, a narrow cutout in the fence holds the flush trim bit that's used to trim the edging.

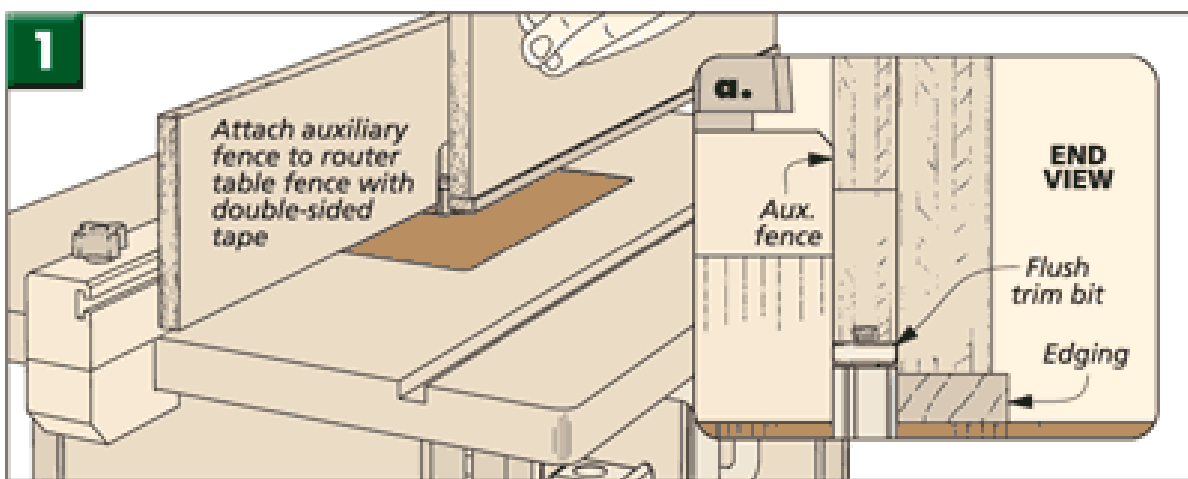

Once the auxiliary fence and the flush trim bit are in place, the edging on the panels can be trimmed with a single pass along each side. The result is a great-looking panel.

Have a great weekend, Ted Raife
Editor, *Woodsmith*