

WOOD CHIPS



Northwest Indiana Woodworkers Association
Volume 19, Issue 5 May 2015

President's Ramblings

Greetings Fellow Woodworkers, May is here and the weather has been changing, for the good and bad. The grass is growing too fast to keep up with. I had a small problem with my heart last week, so far everything has checked out. I attended a Sketch Up class at Marc Adams School of Woodworking early this month. Bob Lang, former Contributing Editor for Popular Woodworking and author of many articles and books on Sketch Up, was our instructor for the weekend. What a blast to have the opportunity to attend a class there. I have the instruction book and video that Bob used to teach the class with and 16 hours of video. If there is interest I could do a Sketch Up basic class before our regular club meetings. We can all learn together, I am no expert but did pick up some good tips.



Marc Adams School



Instructor – Bob Lang (with pony tail)



Sketchup Class



Workshop

As of our May Committees Meeting I need to remind the membership that Dues are Due this month, May is membership renewal month, please see Ron Benson for your 2015 membership card. Also the Educational Raffle is in full swing. If you can, get some extra tickets to sell to your friends and neighbors. Tickets are 1 for \$2.00 or 3 for \$5.00, every little bit helps!!! Ron has lots of cars that need to be finished, please do what you can to put a finish on a car or two. These have been donated to our club for the Educational program as a fund raiser.

ATTENTION ALL MEMMBERS! Most of these jobs don't take a lot of time, a few hours a month.

May's Program will be on sanding by our own expert, Fred Bogwell. June's Program will be on Sharpening, presented by Don Good. Bring some tools to the meeting for tips on putting a fine edge on them. July's Program is on Chain Saw Carving with Jeff Postma. Thank you Jeff Snellgrove for making the arrangements for our programs.

Lake County Fair is coming soon, August 7th-16th, 2015. We will be setting up on Thursday the 6th and tear down and clean up will be Monday the 10th at 9:00 PM. Please sign up to help in the booth and demonstrate your talents. We can always use ambassadors to help promote Your club!

Passing this on from Denny McCoole;

We are going to have a demo put on by Ray from Illiana Wood Turners club on cutting segments for turning on May 30th at my shop at 9 AM. For more information contact Denny McCoole.

In closing, Renew your membership, Raffle tickets, Enjoy this weather and Don't let your tools rust!

Your President

Kevin Sturgeon

From the Treasurer

Fellow NWIA club members; The month of May is dues year for 2015/2016. Dues still only \$25.00. Get an achievement point buy paying at this meeting night. Your dues are what helps your club to be a successful club. Bills need to be paid for items such as, gift cards, news letter, picnic, Christmas party, demos from wood working organizations, and many other things.

Also, raffle tickets are available too. Get some to sell or buy. You can pick some up at a meeting or by calling Ron Benson at 219-762-8416, or e-mail me at; rnivars@msn.com . I can mail some to you. Tickets are \$2.00 each or 3 for \$5.00. There are some great prizes to be won. The raffle project helps our toy program and education.

Ron Benson

SHOW AND TELL



Gene Davis



Jesse Day



Denny McCool



Kevin Sturgeon



Dick Sader

2 X 4 CHALLENGE



Jeff Snellgrove



Jesse Day

ITEMS FOR SALE

If you have any wood working related items that you wish to sell through the newsletter please contact John Hunter john.b.hunter@frontier.com Include a description and the price you are selling them for, also how you may be contacted.

If you are looking for a tool that another member would like to sell you can place a wanted ad in the newsletter, just contact John Hunter at john.b.hunter@frontier.com

CALENDAR OF EVENTS 2015

May 28th Membership Meeting at 208 South Linda Street, Hobart IN 7:00 PM

Program – Sanding by Fred Bogwell

June 16th Committees Meeting at 2949 Willowcreek Rd, Portage 7:00 PM

June 25th Membership Meeting at 208 South Linda Street, Hobart IN 7:00 PM
Program – Tool Sharpening with Don Good

July 13th Executive Board Meeting 7 PM at 2949 Willowcreek Rd, Portage

July 21st Committees Meeting at 2949 Willowcreek Rd, Portage 7:00 PM

July 23rd Membership Meeting at Hidden at 208 South Linda Street, Hobart IN 7:00 PM
Program - Jeff Postma Chainsaw Carving

August 6th Set Up Club Booth at Lake County Fair 9 PM

August 7th – 10th Club Booth at Lake County Fair 10 AM – 10 PM

August 18th Committees Meeting at 2949 Willowcreek Rd, Portage 7:00 PM

August 22nd Club Picnic at Hidden Lake Park 12 Noon

August 27th Membership Meeting at 208 South Linda Street, Hobart IN 7:00 PM
Program - Favorite/Least Favorite Tool Program

September 15th Committees Meeting at 2949 Willowcreek Rd, Portage 7:00 PM

September 24th Membership Meeting at 208 South Linda Street, Hobart IN 7:00 PM

October 5th Executive Board Meeting at 7 PM at 2949 Willowcreek Rd, Portage

October 20th Committees Meeting at 2949 Willowcreek Rd, Portage 7:00 PM

October 22nd Membership Meeting at 208 South Linda Street, Hobart IN 7:00 PM

November 17th Committees Meeting at 7:00 PM

November 19th Membership Meeting at 208 South Linda Street, Hobart IN 7:00 PM Toy
Program

December 15th Committees Meeting at 2949 Willowcreek Rd, Portage 7:00 PM

December 17th Membership Meeting at 208 South Linda Street, Hobart IN 6:00 PM
Christmas Party, Installation and Awards

Bob Flexner's Finishing Tips

<http://www.thefinishingstore.com/>

Soy-Gel Paint Stripper

The soy-gel paint stripper sold by The Finishing Store is an excellent product. It uses n-methyl pyrrolidone (NMP) as the active stripping ingredient. Many of the most effective alternative strippers (alternative to methylene-chloride and flammable-solvent strippers) are based on NMP.

You need to be aware, however, that NMP works slowly, much more slowly than methylene chloride or flammable solvents. In the early 1990s, a number of manufacturers introduced stripping products based on NMP and claimed working times similar to methylene-chloride and flammable-solvent strippers. This resulted in NMP strippers getting the reputation of “not working,” and the market dried up.

Slow working is related to slow evaporating, and slow evaporation is the real advantage of soy-gel paint remover. If you give it time, it will remove five or ten coats of paint with

only one application. You can't do this with the faster-evaporating, traditional paint strippers. They evaporate so fast that you don't have time to remove more than a coat or two at a time. You're always fighting the fast evaporation rate.

Soy-gel won't evaporate from the surface for days, so the trick using this stripper is to test now and then with a putty knife to see if all the coats have been loosened from the wood. For many coats of paint, it may take a day or two for this to happen. But once it has, the coats of paint are easy to remove.

Low-Cost, Portable Edge Sander



I use a sanding drum on my drill press to smooth curved edges. But on larger projects, it's easier to bring the drum to the workpiece. The edge sander you see here uses a corded drill to power the sanding drum. A cradle holds the drill square to the workpiece. With a few pieces of hardwood, plywood, a dowel, and a couple of hose clamps, you can build your own portable edge sander.

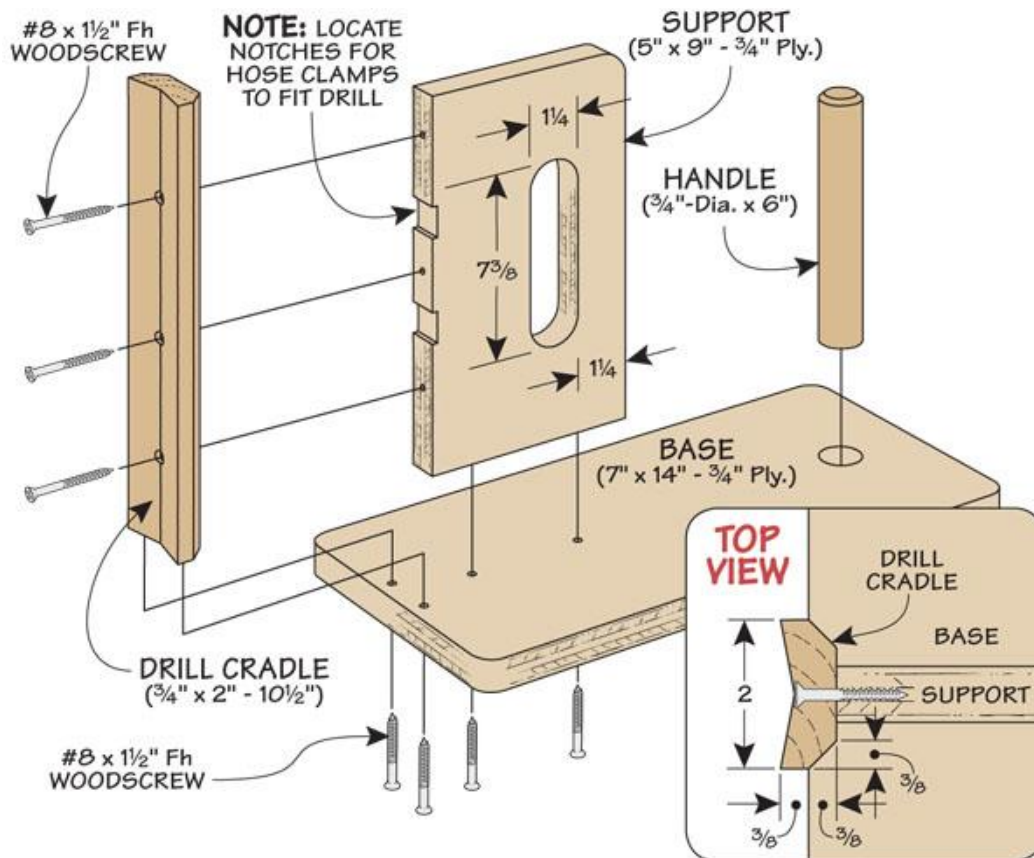

This drawing shows you how the sander is put together. It starts with the base that provides a large platform for steadying the sander when smoothing an edge.

After adding a dowel to act as a handle, you can work on the cradle that holds the drill. Two shallow bevels form a “V” to hold the drill. A third piece acts as a support and forms another handle for additional control.

Finally, two large hose clamps securely lock the drill into position. Just make sure the sanding drum is square to the base (use shims if necessary to adjust the drill’s position).

This edge sander will become one of your go-to tools in the shop for getting smooth edges.

From Woodsmith Tips; <http://www.woodsmithtips.com/>