

# WOOD CHIPS



Northwest Indiana Woodworkers Association

Volume 16, Issue 3 March 2012

## President's Corner

Greetings members! We have been having a perfect spring for woodworking. I am sure you have been busy in the yard and the shop. While you're at it look around for any library books, DVDs that maybe under a stack of papers. We are planning to inventory the library and we need things back. Also if you feel something from our library is really outstanding, let us know so we can put a review in the newsletter.

Don't forget the 2x4 challenge. This is a fun thing. Build that special something and bring it to the challenge.

The Education Committee is gearing up for the fundraiser. Please donate something nice for the prizes.

See you at the meeting.

Make fine sawdust!

Marcia Lichnerowicz

**Carving SIG** We will be carving at 6pm before the monthly meeting. Bring your projects and questions. New spring project will be shown. It's fun and not difficult!

**Carving Show** April 14 & 15 Woodland Park Pavilion, 2100 Willow creek Rd. Portage, IN Sat. 10am -5pm, Sun. 10am to 4pm. Admission \$4.00 and children under 16 free with parents. Tickets are good for both days.

**Newsletter Update** Those that receive their newsletter through the US Mail may have noticed that we printed the last two issues in color. Although it made for a nice looking newsletter the cost of color printing was found to be too costly so the hard copies are going back to black and white. Those that get their newsletter via the Internet will notice no change.

## SHOW AND TELL



Kevin Sturgeon



Kenneth Garbe



Max Hernick



Gene Davis



Bob Miller



Bob Rinearson



Mike Clark



Chuck Norrman



Denny McCoole



John Hunter

### SHOP JIGS



John Hunter



Skip Brazil



Denney McCoole



Dick Sader



Max Hernick



Kevin Sturgeon



Kevin Sturgeon

## **CLUB FUNDRAISER**

We now have our educational raffle tickets ready for sale to all whom would like to sell or buy them. The wood club is also looking for craft items to give out as prizes. Please see Ron Benson or Norm Johnson at a meeting for tickets or to turn in a craft item. Tickets are \$2.00 or three for \$5.00. There is a total of 1000 to be sold. Let's make this

our best ever. The more money in our gaming account, the better our getting speakers and educational programs.

## SHOP VISIT

Member Gene Davis is hosting a shop visit on March 24<sup>th</sup>, 2012 starting at 10 AM  
Gene's shop is located at 461 East 200 North Valparaiso, IN 46383-9301

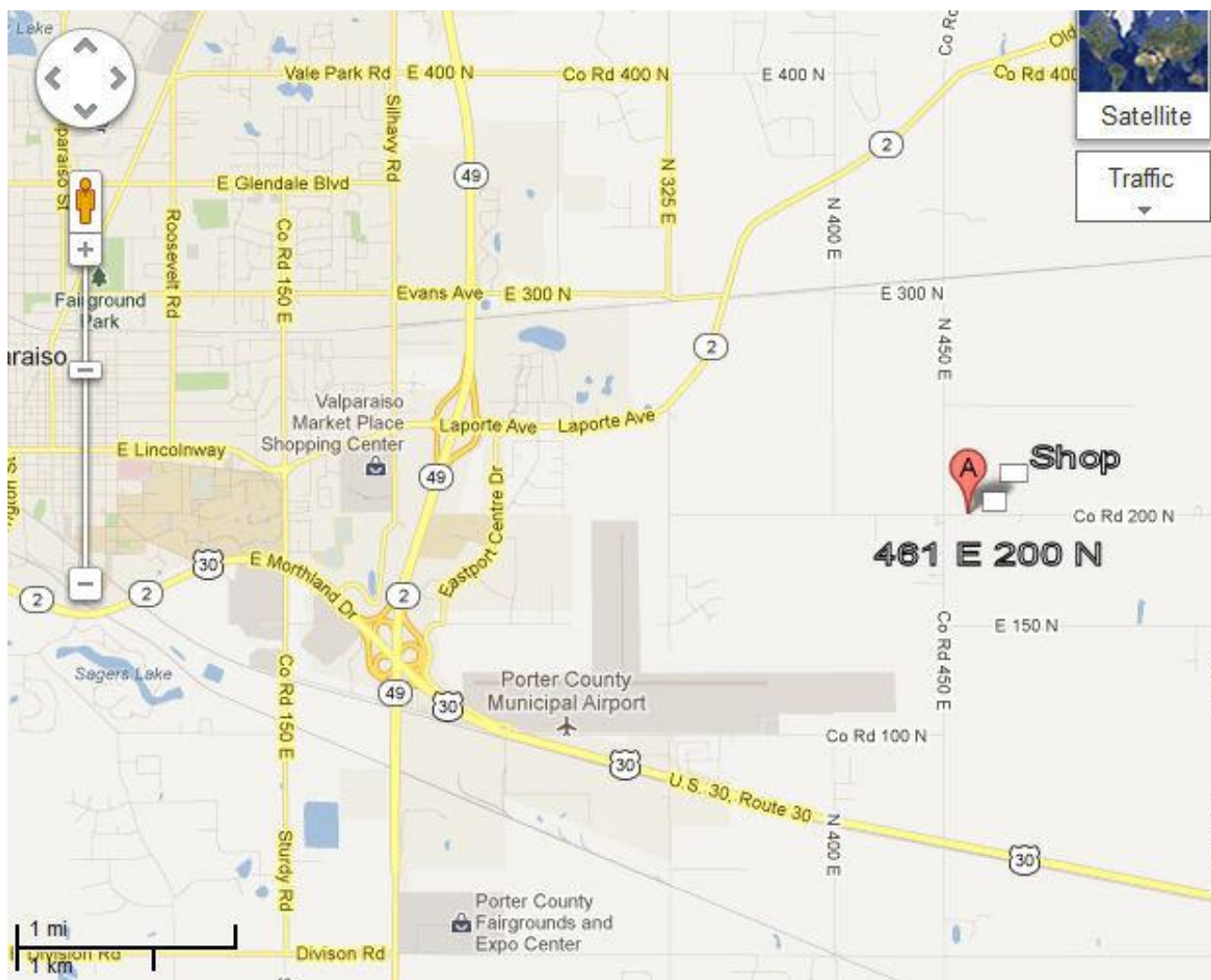

## A WAY TO HELP OUR MILITARY

Wendy Sader the wife of our vice president Dick Sader has a great way to help our military families. Here is her request;

I am collecting current or EXPIRED (up to six months) newspaper, magazine or computer generated coupons anyone might have. I am collecting them to send to a U.S. Navy family in Guam. I went through a web site

(couponstotroops.com) and was matched up with this family. They will receive the coupons I send and what they don't need will take to a central location on the base and leave them for other families.

After being a military family for over 20 years and knowing how little these families income might be and the other sacrifices they make, like time apart and being so far away from their family and friends, I just want to help in a small way to make their lives a little easier.

If anyone has useable coupons, again current or **expired up to six months**, cut out or still in the inserts from the newspaper, and they can bring them to each meeting for Dick to bring home, I would be very grateful.

Thanks,

Wendy

## **ITEMS FOR SALE AND WANTED**

**If you have any wood working related items that you wish to sell through the newsletter please contact Lalo Gonzalez [LaLogon@sbcglobal.net](mailto:LaLogon@sbcglobal.net) or John Hunter [john.b.hunter@frontier.com](mailto:john.b.hunter@frontier.com) Include a description and the price you are selling them for, also how you may be contacted.**

**If you are looking for a tool that another member would like to sell you can place a wanted ad in the newsletter, just contact John Hunter at [john.b.hunter@frontier.com](mailto:john.b.hunter@frontier.com)**

## **CALENDAR OF EVENTS**

**2012**

March 22<sup>nd</sup> Membership Meeting at Hidden Lake 7:00 PM Garry Graves Kreg Jigs  
April 17<sup>th</sup> Committees Meeting at Hidden Lake 7:00 PM  
April 26<sup>th</sup> Membership Meeting at Hidden Lake 7:00 PM 2 x 4 Challenge  
May 15<sup>th</sup> Committees Meeting at Hidden Lake 7:00 PM  
May 24<sup>th</sup> Membership Meeting at Hidden Lake 7:00 PM  
June 19<sup>th</sup> Committees Meeting at Hidden Lake 7:00 PM  
June 28<sup>th</sup> Membership Meeting at Hidden Lake 7:00 PM  
July 2<sup>nd</sup> Executive Board Meeting at Portage Library 7 PM  
July 17<sup>th</sup> Committees Meeting at Hidden Lake 7:00 PM  
July 26<sup>th</sup> Membership Meeting at Hidden Lake 7:00 PM

August 2<sup>nd</sup> Set Up Club Booth at Lake County Fair 9 PM  
August 3<sup>rd</sup> – 6<sup>th</sup> Club Booth at Lake County Fair 10 AM – 10 PM  
August 21<sup>st</sup> Committees Meeting at Hidden Lake 7:00 PM  
August 23<sup>rd</sup> Membership Meeting at Hidden Lake 7:00 PM  
August 26<sup>th</sup> Club Picnic at Hidden Lake Park 12 Noon  
September 18<sup>th</sup> Committees Meeting at Hidden Lake 7:00 PM  
September 27<sup>th</sup> Membership Meeting at Hidden Lake 7:00 PM  
October 1<sup>st</sup> Executive Board Meeting at Portage Library 7 PM  
October 16<sup>th</sup> Committees Meeting at Hidden Lake 7:00 PM  
October 25<sup>th</sup> Membership Meeting at Hidden Lake 7:00 PM  
November 20<sup>th</sup> Committees Meeting at Hidden Lake 7:00 PM  
November 15<sup>th</sup> Membership Meeting at Hidden Lake 7:00 PM Toy Program  
December 18<sup>th</sup> Committees Meeting at Hidden Lake 7:00 PM  
December 20<sup>th</sup> Membership Meeting at Hidden Lake 7:00 PM Christmas Party,  
Installation and Awards

### **Bob Flexner's Finishing Tips**

<http://www.thefinishingstore.com/>

#### **TIP: Test for Good Bond**

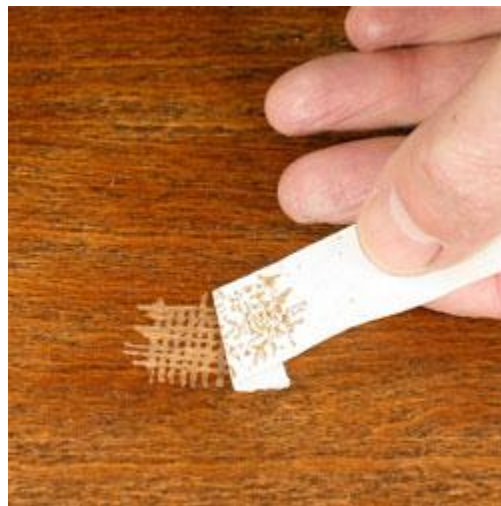

There are a couple of good tests you can perform to see if a finish you are using bonds well to whatever is underneath—oily wood, stain, filler glaze or whatever.

The better test is called the “cross-hatch” test. Using a razor blade or box cutter score the finish (on scrap wood, of course) in a cross-hatch pattern: half-a-dozen cuts about a millimeter apart running in one direction and half-a-dozen cuts in the perpendicular direction.

Then press masking or Scotch tape onto the cut pattern and lift it quickly. If the cuts remain fairly clean, you have a good bond. If the cut lines are jagged, the bond isn't as good. If some of the tiny squares transfer to the tape, you have a very poor bond.

The picture shows a very poor bond.

The second testing method is quicker but may require some experience to interpret accurately. Take a coin and draw it hard across an inch or two of the finish. Does it merely dent the finish (a good bond), or does it tear up and remove the finish (a poor bond)?

## Shop-Built Mobile Tool Base

My shop is small, so I need to be able to move my power tools easily. But manufactured tool bases are a bit more than my budget allows.

So I built a mobile tool base out of some scrap stock. All the hardware can be found at any home improvement center or hardware store. And it goes together quickly and easily.

First you'll want to measure the base of the tool it's going to support. And then cut the four 2x4s so they fit these dimensions.

The base frame is made by simply making half-laps at each corner, like you see in the illustration above. The half-lap joints make a strong level support surface for the tool.

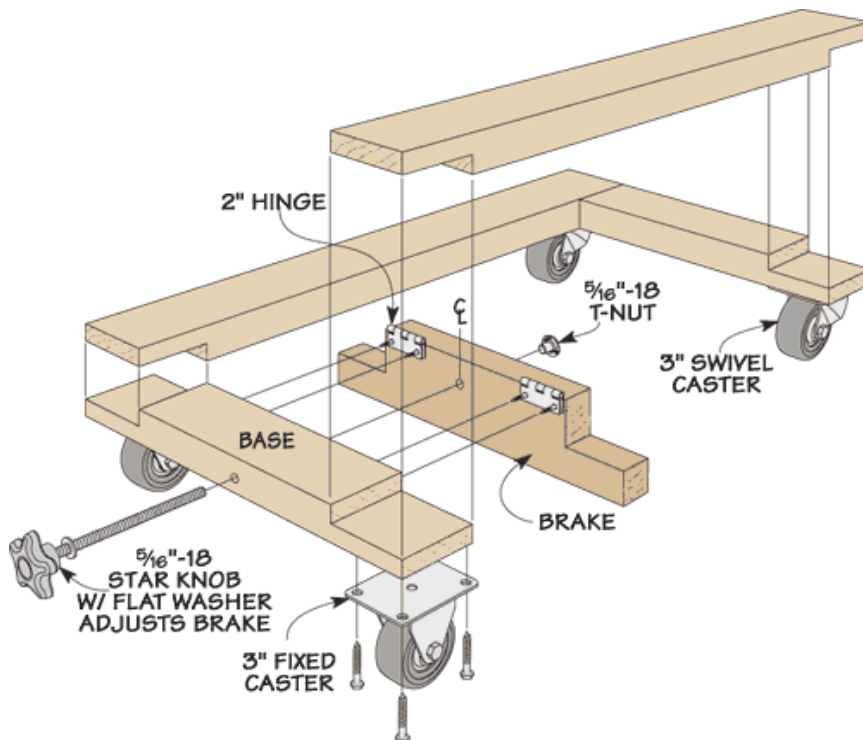



Since it's important to lock the mobile base in position when I use the tool, I made a simple brake by mounting a pair of hinges at one end of the base and attaching a brake piece.

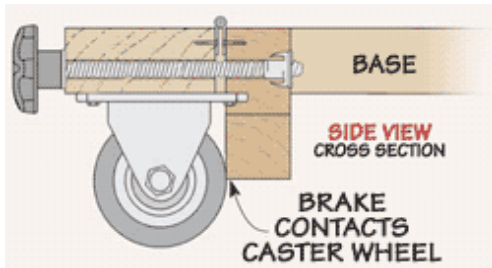

The brake adjustment is nothing more than a hole drilled through one end of the base and the hinged 2x4. A T-nut, threaded rod, and star knob (*see illustration side view at right*) were added to complete the adjustment assembly. Then by tightening the knob, the wooden brake is pulled against the castor wheels with enough force to keep the wheels locked in place.

Finally, I used lag screws to attached the tool securely to the base. Just be sure it's securly fastened before you try to move it.

Good Woodworking,

Phil Huber

Online Editor, *ShopNotes*

## Driving Screws into MDF

I often use medium-density fiberboard (MDF) for my shop jigs and fixtures. There are many things I like about MDF. It's stable, heavy and costs about *half* as much as cabinet-grade plywood.

One thing I *don't* like about MDF is its tendency to split along the edge of a workpiece. But, luckily, there are a couple of things you can do to avoid this problem.



MDF tends to split most often when drilling and screwing in its edge, especially when using a *tapered* woodscrew, left above. It acts like a wedge to drive the workpiece apart. So I've gotten into the habit of using a *straight-shanked* screw, right above.

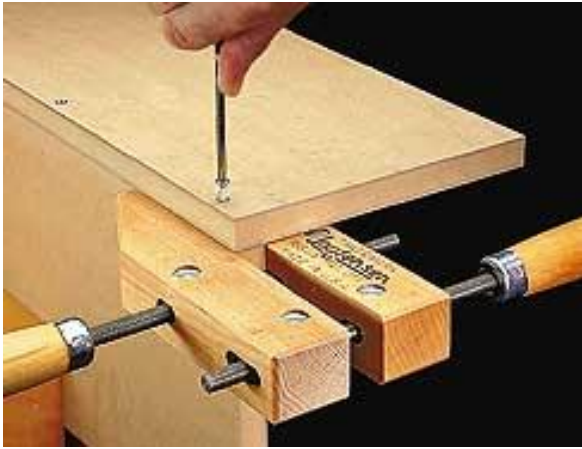

However, a straight-shanked screw isn't a cure-all. Even when using a pilot hole and the right screw, MDF can still split out. So one final precaution is to support the sides by clamping an ordinary handscrew across the workpiece, see the photo at left. It makes it almost impossible to split the MDF.

Try these two tips the next time you're working with MDF and you shouldn't have any problems with splitting.

## HUMOR

### Ten Signs You May Be Spending Too Much Time in the Shop

1. Your garage is absolutely off limits to cars.
2. Family members must wear name tags.
3. Your friends stop using your real name; instead they call you "Norm".
4. Sawdust deposits have turned your entire back yard into a compost pile.
5. Instead of removing splinters, you simply let them wear away with the calluses.
6. Your dog growls when you enter the house.
7. Your finishing room is about to become a Superfund site.
8. The pile of pizza boxes outside your shop is taller than you are.
9. You have filled every room in the house with furniture and are actually considering yard ornaments as future projects.
10. You have no idea who Seinfeld is.

