

WOOD CHIPS



Northwest Indiana Woodworkers Association

Volume 18, Issue 6 June 2014

President's Corner

Greetings Woodworkers, I am back from an interesting trip to Sedona AZ. There was a big forest fire. We were at the park minutes before the fire broke out but decided to come back the next day since it was getting late. The resort was 5 miles away but we never had to evacuate. Thank goodness no one was killed in the fire. 20,000 acres burned. Wow. Glad to get back to my friends here at NIWA. A **BIG thank you to** Kevin, our VP, for directing May's Monthly Meeting.

I am sad to say that Charlie Morris has left us and has joined our great carpenter Jesus in heaven. He will be missed. I always enjoyed his jokes and smile that lit up a room. He was a wiz kid with the router and had the collection to prove it. He loved his wife, dogs and woodworking. God Bless you Charlie. It is a privilege to have known you.

Don't forget, Bob Miller and his wife Sandy are having a shop visit on Sunday, June 29 from 12pm to 4pm. Bob always has something interesting going on in the shop!

Thank You Rich Rossio for putting on a great program. I wish I was there. It was so nice to see you at the carving show. I am enclosing your email and phone number in case members want to contact you. disorder@aol.com and 815-838-7686.

Make Fine Sawdust Always!

Your President,

Marcia Lichnerowicz

Toy Program While the weather is good many members are making toys for our toy give away in November. Keep your ears open for a group that can distribute them. Give the information to one of the executive board members. It's not too early. If you are making cradles we need to know the size of the base so a mattress and blanket can be made to fit in time. Please give this information to Marcie. She will be working on this. We have many parts for the toys if you need them. Contact John Hunter or Ron Benson.

Picnic Sign Up We need the name & amount of people coming to the picnic. We have to turn the information in to Hidden Lake so you will be able to get in free. The date of the Picnic is Sunday, August 31.

June Program Member Mike Clark will go through frame making. This will be an interesting program. We all know there is always need to make a frame.

A Member Passes



As most members have heard, Charlie Morris one of the clubs Life Members recently passed away. Charlie was a great woodworker and a close friend. As a matter of fact it was Charlie that introduced me to woodworking and brought me to the club. Charlie always enjoyed working the club booth at the Lake County Fair. He especially enjoyed demonstration the magic belt hanger to the kids. It was Charlie's request that no funeral or services be held for him. We will all miss him.

Charlie's wife Bonny is having a gathering of Charlie's friends on Saturday June 28th at 5 PM at the Fifth Street Club in Wheeler Indiana. 110 N 5th St, Wheeler, IN 46393

RIP Charlie,

John Hunter

SHOP VISIT

Bob Miller is hosting a shop visit on Sunday June 29th from 12:00 – 4:00. His address is 205 N 450 E Valparaiso Indiana. Located 1.5 miles North of US 30 on 450 E or 1.9 miles South of Route 2 on 450 E. Bob is going to demonstrate quarter-sawing on his sawmill at approximately 1:30 during the shop visit.

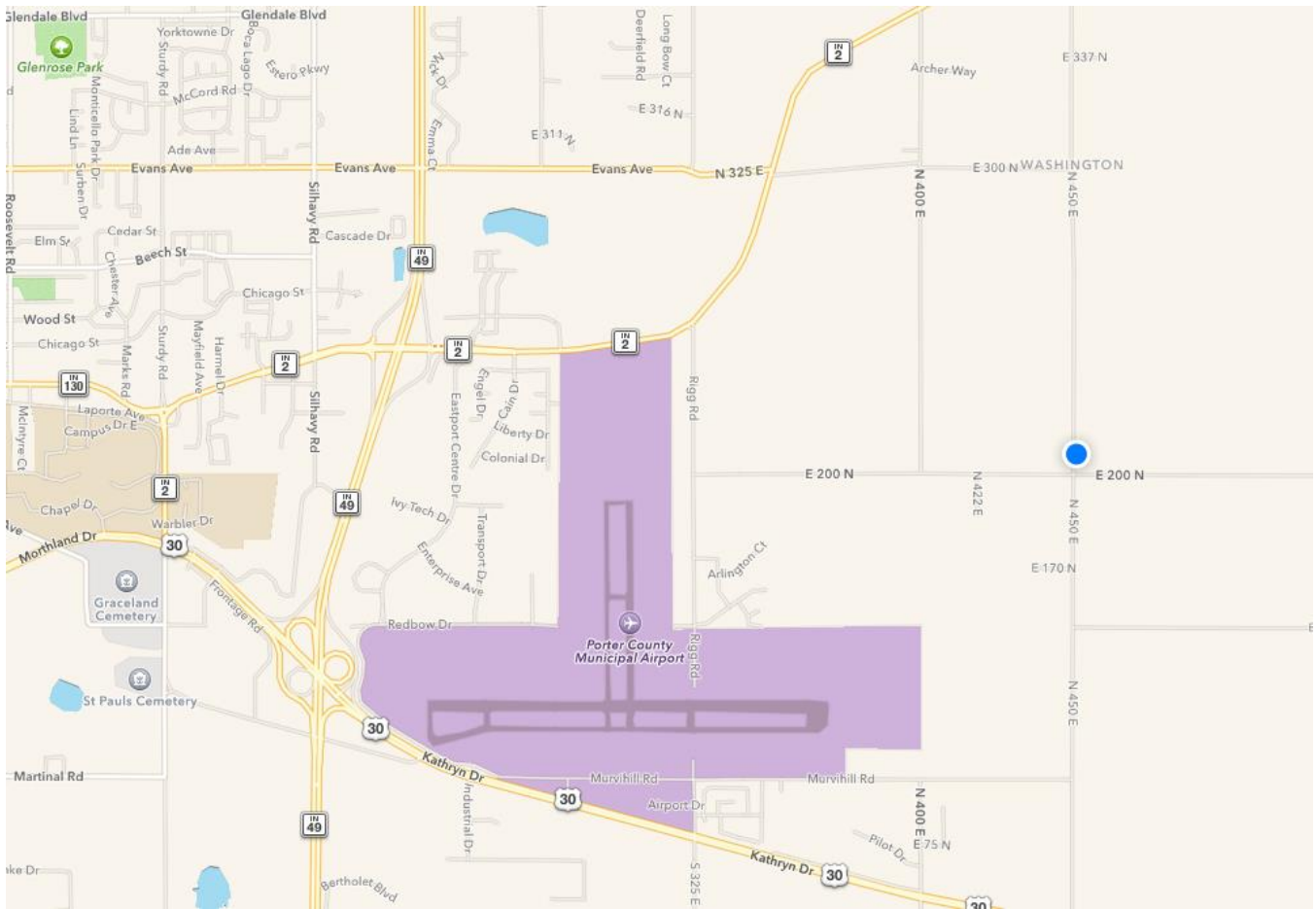

SHOW AND TELL



Dave Skaggs



Frank Berzinis



Denny McCool



Jon Robbins



Ron Benson



John Hunter



Ken Woolard



Kevin Sturgeon

PROGRAM

Our speaker was Richard Rossio who demonstrated offset turning. It was a very interesting demo. He can be contacted at disoorder@aol.com or (815) 838-7686 home phone number.



ITEMS FOR SALE

If you have any wood working related items that you wish to sell through the newsletter please contact John Hunter john.b.hunter@frontier.com Include a description and the price you are selling them for, also how you may be contacted.

If you are looking for a tool that another member would like to sell you can place a wanted ad in the newsletter, just contact John Hunter at john.b.hunter@frontier.com

CALENDAR OF EVENTS

2014

- June 26th Membership Meeting at Hidden Lake 7:00 PM
- June 29th Shop Visit at Bob Millers 12 Noon until 4 PM
- July 7th Executive Board Meeting 7 PM at 2949 Willowcreek Rd, Portage,
Gray house on corner. Sign out front says [Family Center]
- July 15th Committees Meeting at 2949 Willowcreek Rd, Portage 7:00 PM
- July 24th Membership Meeting at Hidden at Hidden Lake 7:00 PM
- July 31st Set Up Club Booth at Lake County Fair 9 PM
- August 1st – 4th Club Booth at Lake County Fair 10 AM – 10 PM
- August 19th Committees Meeting at 2949 Willowcreek Rd, Portage 7:00 PM
- August 28th Membership Meeting at Hidden Lake 7:00 PM
- August 31st Club Picnic at Hidden Lake Park 12 Noon
- September 16th Committees Meeting at 2949 Willowcreek Rd, Portage 7:00 PM
- September 25th Membership Meeting at Hidden Lake 7:00 PM
- October 6th Executive Board Meeting at 7 PM at 2949 Willowcreek Rd, Portage,
Gray house on corner. Sign out front says [Family Center]
- October 21st Committees Meeting at 2949 Willowcreek Rd, Portage 7:00 PM
- October 23rd Membership Meeting at Hidden Lake 7:00 PM
- November 18th Committees Meeting at 7:00 PM
- November 20th Membership Meeting at Hidden Lake 7:00 PM Toy Program
- December 16th Committees Meeting at 2949 Willowcreek Rd, Portage 7:00 PM
- December 18th Membership Meeting at Hidden Lake 6:00 PM Christmas Party,
Installation and Awards

TIP: Gun Stock Finish

The most popular homeowner gunstock finish is probably Tru-Oil. You can get it at almost every store that sells guns.

Tru-Oil is polymerized linseed oil. It is linseed oil that has been cooked at high temperatures in an oxygen-free environment (inert gases) until it just begins to gel, then rapidly cooled. The cooking causes the carbon atoms to begin crosslinking. So when the finish is later exposed to oxygen in the air during the finishing process, the finish cures very rapidly.

After the cooking the oil is very thick so the manufacturer adds mineral spirits to make the finish easier to apply. You can add more mineral spirits if you like.

Tru-Oil is oil, but it acts more like varnish. It can even be built up like varnish, but only with very thin coats or it will crack. Gun owners like to “rub in” the finish anyway, even though no more finish enters the wood after the first coat has dried, and this removes most of the excess. So thick finishes aren't generally a problem.

Let each coat dry hard (a few hours in a warm room), sand off any dust nibs if there are any, then apply more coats until you get an appearance you like. If the finish is glossier than you want, dull it by rubbing with #0000 steel wool.

Sandpaper Cutter



Standard sandpaper comes in 9" x 11" sheets. But this is rarely the size that I need. Most often, I end up dividing a sheet into smaller pieces to fit my sander or a sanding block. For a long time, I made do with simply folding the sandpaper and then tearing it. But this crude method often gave me less than satisfactory results. So I decided to come up with a more reliable way to do the job.

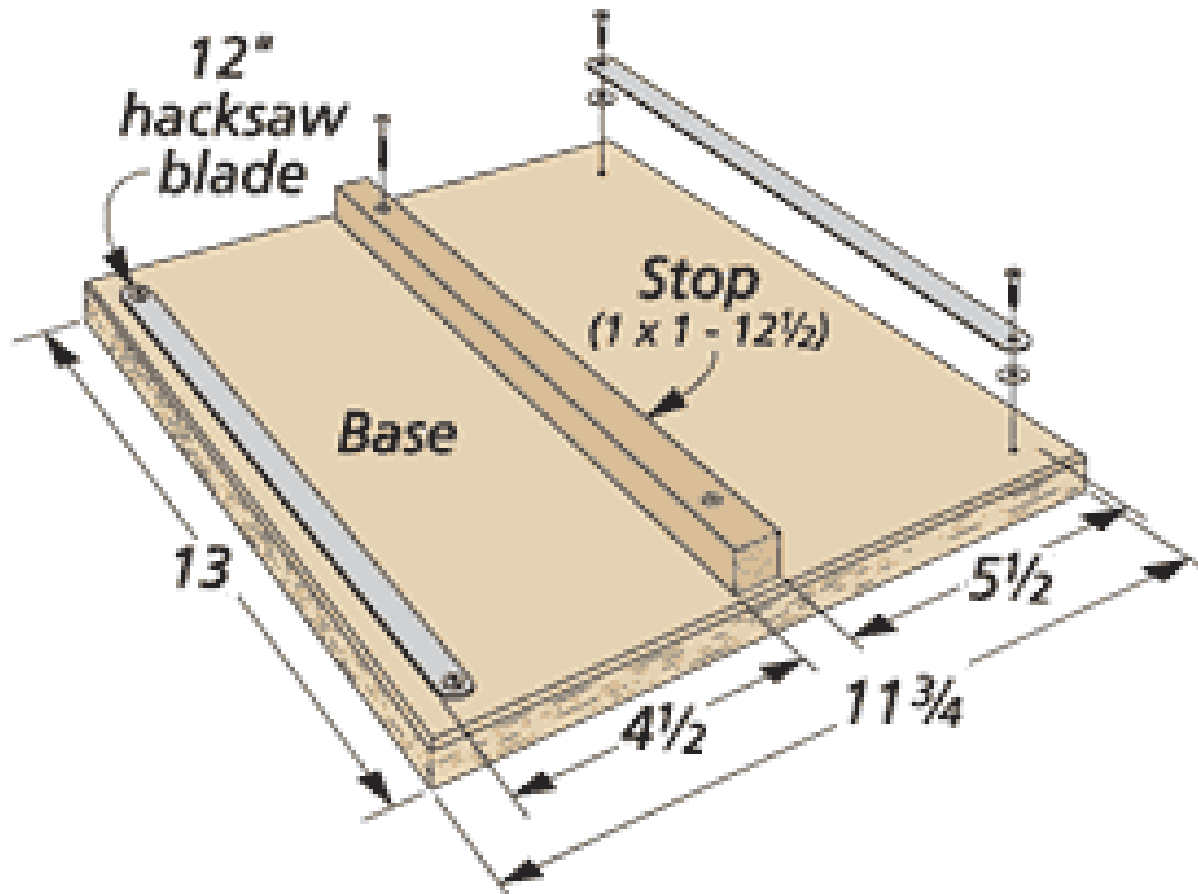

The sandpaper cutter in the drawing at right is the fruit of my efforts. A hacksaw blade attached to each side of a plywood base acts as the cutter. A thin washer at either end of the blade spaces it just above the base. Then an off-center length stop fastened to the base gives me a couple of size options for my cuts.

To cut a sheet to size, you slide it under the hacksaw blade against the stop and tear. The cuts are quick, clean, and accurate. It's a great solution to a common problem.

Good Woodworking,

Ted Raife
Online Editor, *Woodsmith*