

WOOD CHIPS



Northwest Indiana Woodworkers Association

Volume 20, Issue 7 July 2016

President's Ramblings

Greetings Fellow Woodworkers, The end of July is upon us and I hope everyone is staying cool and well hydrated during this heat wave. August is just around the corner which brings us to Lake County Fair time. I hope to see everyone at our booth some time through the weekend. Our schedule for the fair is Thursday August 4th at 9 pm for set up, Friday the 5th through Monday the 8th from 10 am to 10 pm to put on demonstrations and talk about our club. Then take down on Monday at 9 pm. Remember to sign in each day to get credit for the Awards Program. **WE ARE IN NEED OF VOLUNTEERS TO MAN THE BOOTH! SIGN UP SHEET WILL BE AT THURSDAY'S MEETING.** We have a place that has been offered to us that we can get out of the heat if you need.

Annual Club Picnic is coming up on Saturday, 8/27/16 at Noon. Same location as before, **Hidden Lake Park in Merrivillie, IN.** The club will be providing Hot Dogs, Hamburgers, Chicken, Water and Pop. Bring a covered dish and a gift for the BINGO. So far only a handful of members have signed up for the picnic. We need to turn in your name to the park office if you want to attend or you will be charged the entrance fee. To avoid this, sign up at Thursday's meeting or contact/email John Hunter john.b.hunter@fdrontier.com before August 18th to be included on the list.

Program for July is our Four Corners. There is still an opportunity if you are interested in sharing a skill that would help the members in their shops!

Other upcoming event, Indiana Woodcarvers Summer Camp is August 11-14, 2016 at Pla-Mor Campground in Bremen, Indiana.

Enjoy this weather and Don't let your tools rust!

Your President,

Kevin Sturgeon

From the Treasurer

Fellow woodworkers; All club dues were due in May. Dues are still only \$25.00 per year. If you want to continue getting the newsletter and other notifications, you need to pay your dues. So far only 43 members have paid their dues. The club raffle program still needs members to sell tickets. These funds go for our educational, toy program, speakers and such. Please remit as soon as you can. Ron Benson, Treasurer

SHOW AND TELL



John Arvidson



Bill Schoech



Jesse Carrillo



Don Bunce



Frank Schmidt



Ken Garbe



Mike Clark



Jon Robbins



John Novak



Frank Berzinis



Ron Benson



Jeff Snellgrove



Kevin Sturgeon, Matt Castro & Renee Castro

BEAR CHAINSAW CARVINGS

At our last meeting Frank Schmidt told about the bear chain saw carvings, he sent me these photos and I thought our members would enjoy seeing them.



Carving of the Bears

The stump was wide enough to carve pappa, momma, and baby except for baby's waving arm. It is about 18' high and took four days to complete with lots of equipment and with loads of saws. The cost was \$3,200

Many watched the operation and it has been well received by all who view it at our town park on Red Arrow Highway in New Buffalo.

Frank Schmidt

ITEMS FOR SALE

If you have any wood working related items that you wish to sell through the newsletter please contact John Hunter john.b.hunter@frontier.com Include a description and the price you are selling them for, also how you may be contacted.

If you are looking for a tool that another member would like to sell you can place a wanted ad in the newsletter, just contact John Hunter at john.b.hunter@frontier.com

CALENDAR OF EVENTS

2016

- July 28th Membership Meeting at 208 South Linda Street, Hobart IN 7:00 PM
- August 4th Set Up Club Booth at Lake County Fair 9 PM
- August 5th – 8th Club Booth at Lake County Fair 10 AM – 10 PM
- August 16th Committees Meeting at 2949 Willowcreek Rd, Portage 7:00 PM
- August 25th Membership Meeting at 208 South Linda Street, Hobart IN 7:00 PM
- August 27th Club Picnic at Post 260, 5675 Mulberry St. Portage IN 46368 12 Noon
- September 20th Committees Meeting at 2949 Willowcreek Rd, Portage 7:00 PM
- September 22nd Membership Meeting at 208 South Linda Street, Hobart IN 7:00 PM
PM Program Favorite/Least Favorite tools
- October 3rd Executive Board Meeting at 7 PM at 2949 Willowcreek Rd, Portage
- October 18th Committees Meeting at 2949 Willowcreek Rd, Portage 7:00 PM
- October 27th Membership Meeting at 208 South Linda Street, Hobart IN 7:00 PM
- November 15th Committees Meeting at 7:00 PM
- November 17th Membership Meeting at 208 South Linda Street, Hobart IN 7:00 PM
PM Toy Program
- December 13th Committees Meeting at 2949 Willowcreek Rd, Portage 7:00 PM
- December 15th Membership Meeting at 208 South Linda Street, Hobart IN 6:00 PM
PM Christmas Party, Installation and Awards

Removing Wax Smear

Paste wax is easy enough to apply. Simply wipe it on the surface.

The problem comes in removing the excess wax, because if you don't remove all the excess it leaves a smear rather than a shine, as shown in a somewhat exaggerated form in the picture.



The trick is to use a clean cloth or lambs-wool pad for the removal—with the emphasis on “clean.” If you continue to wipe off the excess with a cloth or pad that has become loaded with wax, you will just be moving the wax around the surface rather than transferring it to the cloth or pad.

So, whenever the cloth or pad become loaded with wax, refold the cloth to a clean area or replace the cloth or pad with a clean one.

To make removal easier, apply the wax thin to begin with. The easy way to do this is to wrap the paste wax in a cloth so that all that is being applied is the wax that seeps through the cloth.

Fastening Glass Stop

Fastening the stop that holds a pane of glass into a door or frame can be a delicate job. If you're not careful, the brads can split the stop or worse yet, you can break an expensive piece of glass. For this reason, I make it a routine to always pre-drill the holes for the brads.

The only catch to this precaution is that it's hard to drill the pilot holes with the pane of glass in place. There's simply not enough clearance between the glass and the drill.

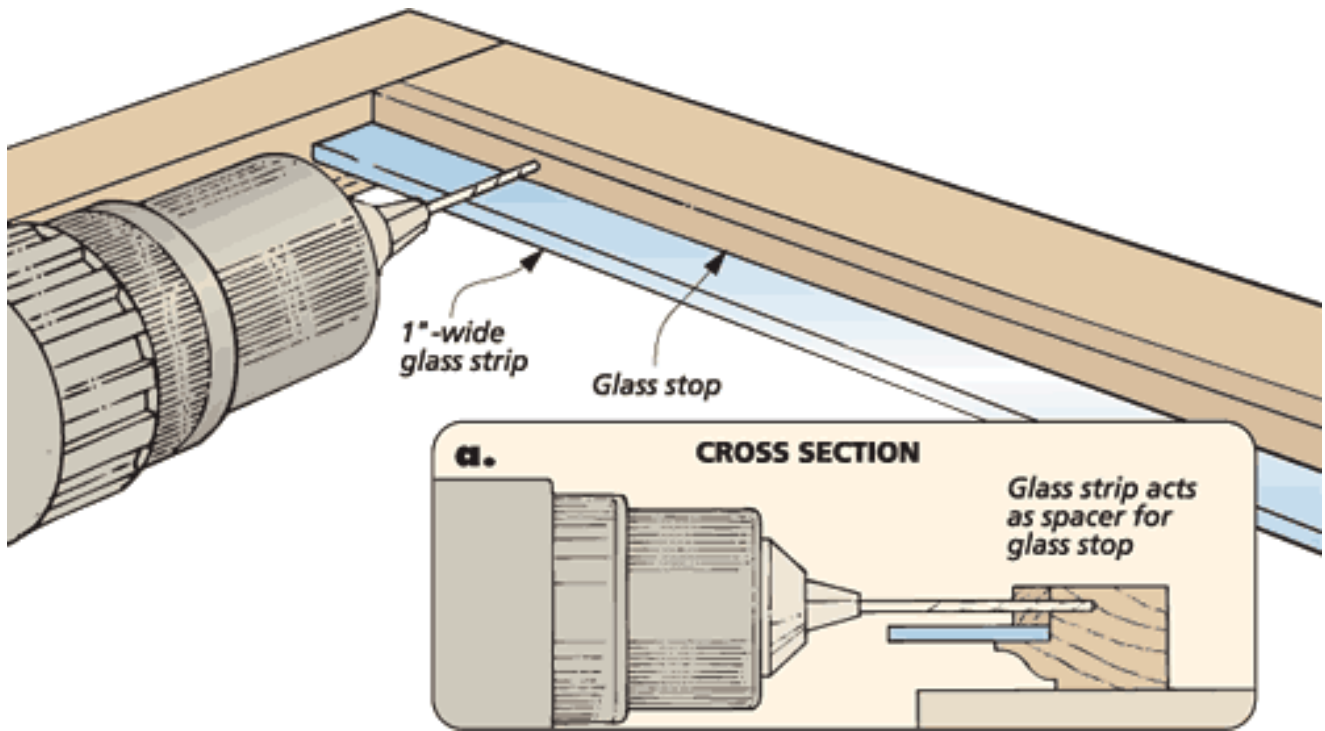

To get around the problem, I started keeping a thin “dummy” strip of glass in the shop. As you can see in the drawings, this strip allows me to position the stop and drill the holes, avoiding the clearance issues. Then the full-size pane of glass can be installed safely and easily.

Good Woodworking,

Ted Raife
 Online Editor, *Woodsmith*



“I like the design.
 Do you happen to have a set of plans?”