

WOOD CHIPS



Northwest Indiana Woodworkers Association

Volume 26, Issue 1 January 2021

President's Rambling's

Greetings Fellow Woodworkers, Happy New Year everyone! I will keep this month's letter short because there is not much happening due to Covid 19. The annual Wood Show has gone to a virtual show, check their web site (<https://www.thewoodworkingshows.com/>) for more information. Also canceled is the **SILENT AUCTION** for January. If there is enough interest we can have this later in the year.

We welcome John Fluck as our new Raffle Committee Chairman. He will be taking over the day to day responsibilities and Ron will still handle the paper work with the state.

You need to check out the wonderful scroll saw cross Dick Sader donated to the Hobart Moose for their Wall of Honor display to our Military men and women. He did a fantastic job.

The Toys for Kids program was a great success! Thanks to all that participated to make this happen. We handed out over 1400 toys this past drive. Congratulations on a job well done.

If this toy program is to continue and other programs, we need each member to buy or sell at least 5 raffle tickets just to cover the prizes. I don't think this is too much to ask for, it would surely help get this year's raffle off to a good start. Our supplies are dwindling down and an order will have to be made and this is how we can do this by selling tickets.

Up coming programs:

SILENT AUCTION canceled for January

January. A Quick look at how to tune up a hand plan.

February's Program is SHOP JIGS.

April Program is the 2 x 4 Challenge.

Any and all ideas for programs would be greatly appreciated.

Enjoy this weather and Don't let your tools rust! Your President, Kevin Sturgeon

From the Treasurer

Fellow wood workers; Your dues for 21/22 can start being collected at the February meeting. Pay early and get an achievement point. Dues are still only \$25.00 or \$35.00 per couple.

Your club now has a RAFFLE chairman by the name of John Fluck. Also Dick Sader said he would be the co-chairman. Thanks to both of them for stepping up. Attendance at our meetings on the 4th. Thursday is not well attended. The Moose Lodge is very clean and covid safe. Masks if you need can be worn and they have sanitizer there. They also have a great fish fry every Friday from 5:30 PM till 7:30 PM. Some of us have been to the fish fry and it is run well with great food. So, come check your new club out this January 28th. at 7:00PM. Thank you Ron Benson

SHOW AND TELL



Jeff Snellgrove



Jon Robbins



Gene Davis



Kevin Sturgeon



Kevin Sturgeon

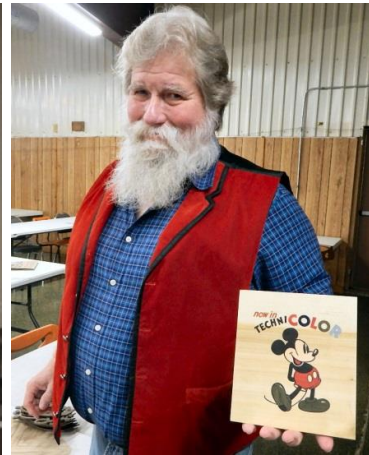

Kevin Sturgeon

GIFT FOR MOOSE LODGE

Member Dick Sader made a plaque to honor veterans and presented to Freddie Rich of the Hobart Moose it is a veterans cross for their Honor wall.



ITEMS FOR SALE

If you have any wood working related items that you wish to sell through the newsletter please contact John Hunter john.b.hunter@frontier.com Include a description and the price you are selling them for, also how you may be contacted.

If you are looking for a tool that another member would like to sell you can place a wanted ad in the newsletter, just contact John Hunter at john.b.hunter@frontier.com

2021

January 28th Membership Meeting at Moose Lodge, 143 South Hobart Road, Hobart IN

7:00 PM How to tune up a hand plan

February 17th Committees Meeting at Moose Lodge, 143 South Hobart Road, Hobart IN

7:00 PM

February 25th Membership Meeting at Moose Lodge, 143 South Hobart Road, Hobart IN

7:00 PM Shop Jigs

March 17th Committees Meeting at Moose Lodge, 143 South Hobart Road, Hobart IN
7:00 PM

March 25th Membership Meeting at Moose Lodge, 143 South Hobart Road, Hobart IN
7:00 PM

April 5th Executive Board Meeting at Portage Moose Lodge on County Line Road

April 14th Committees Meeting at Moose Lodge, 143 South Hobart Road, Hobart IN
7:00 PM

April 22nd Membership Meeting at at Moose Lodge, 143 South Hobart Road, Hobart IN
7:00 PM 2 x 4 Challenge

May 19th Committees Meeting at Moose Lodge, 143 South Hobart Road, Hobart IN
7:00 PM

May 27th Membership Meeting at Moose Lodge, 143 South Hobart Road, Hobart IN
7:00 PM

June 16th Committees Meeting at Moose Lodge, 143 South Hobart Road, Hobart IN
7:00 PM

June 24th Membership Meeting at Moose Lodge, 143 South Hobart Road, Hobart IN
7:00 PM

July 5th Executive Board Meeting 5 PM at Portage Moose Lodge on County Line Road

July 8th Set Up Club Booth at Steam Show 3 PM

July 10th – 11th Club Booth at the Steam Show at Lake County Fair Grounds

July 14th Committees Meeting at Moose Lodge, 143 South Hobart Road, Hobart IN
7:00 PM

July 22nd Membership Meeting at Moose Lodge, 143 South Hobart Road, Hobart IN
7:00 PM

August 5th Set Up Club Booth at Lake County Fair 9 PM

August 6th – 9th Club Booth at Lake County Fair 10 AM – 10 PM

August 18th Committees Meeting at Moose Lodge, 143 South Hobart Road, Hobart IN
7:00 PM

August 21st Club Picnic at Moose Lodge, 143 South Hobart Road, Hobart IN
12:00 Noon

August 26th Membership Meeting at Moose Lodge, 143 South Hobart Road, Hobart IN
7:00 PM

September 15st Committees Meeting at Moose Lodge, 143 South Hobart Road, Hobart IN
7:00 PM

September 23rd Membership Meeting at Moose Lodge, 143 South Hobart Road, Hobart IN
7:00 PM Program Favorite/Least Favorite tools

October 4th Executive Board Meeting 5 PM at Portage Moose Lodge on County Line Road

October 20th Committees Meeting at Moose Lodge, 143 South Hobart Road, Hobart IN
7:00 PM

October 28th Membership Meeting at Moose Lodge, 143 South Hobart Road, Hobart IN
7:00 PM

November 10th Committees Meeting at Moose Lodge, 143 South Hobart Road, Hobart IN

7:00 PM

November 18th Membership Meeting at Moose Lodge, 143 South Hobart Road, Hobart IN

7:00 PM Toy Program

December 8th Committees Meeting at Moose Lodge, 143 South Hobart Road, Hobart IN

7:00 PM

December 16th Membership Meeting at Moose Lodge, 143 South Hobart Road, Hobart IN

6:00 PM Christmas Party, Installation and Awards

Bob Flexner's Finishing Tips

<http://www.thefinishingstore.com/>

TIP: Make Cherry Look Old

One of the great unknowns commonly pursued by woodworkers is how to make new cherry look old without any blotching. Here's a discussion.

The rust-red coloring in old cherry develops over many decades from oxidation accelerated by UV light—and possibly also by an original application of linseed oil that has darkened. You can get part way to this coloring by exposing cherry to sunlight, but only part way. You can also get part way by applying boiled linseed oil, and the wood will darken more as it ages.

But to get all the way, you have to use a dye stain or chemical such as lye, and these colorants cause much more blotching than linseed oil or any other clear finish. Moreover, the dyed cherry will continue to darken, probably leaving you with a color darker than you wanted.



So you have a choice. You can give new cherry the coloring of old cherry, but you may have to live with blotching—depending on the specific boards you're using. Or you can color cherry and avoid much of the blotching by using any combination of UV light, linseed oil, washcoat and stain, toner or glaze. But the cherry won't have both the color and vibrancy of old cherry. You may have noticed that factory-finished cherry furniture is darker than old cherry and also not as vibrant. Factories avoid the blotching problem by using toners and glazes to create the coloring in the finish rather than in the wood and this muddies the appearance of the wood. If there were a way to recreate the color of old cherry without blotching, you can be sure factories would use it because of the beauty and popularity of this wood.

Or you can let the cherry age naturally.

Adjustable Clamping Jig

Using heavy, bulky pipe or bar clamps to glue up small panels and assemblies is not a good match. You need a clamping method that's a better fit to the job.



My solution to this problem is the adjustable clamping jig you see in the photo above. The jig uses two parallel, pivoting arms to trap the workpieces. Clamping pressure is then applied by driving wedges between the arms and a pair of adjustable dowels. It's both

effective and very easy to use.

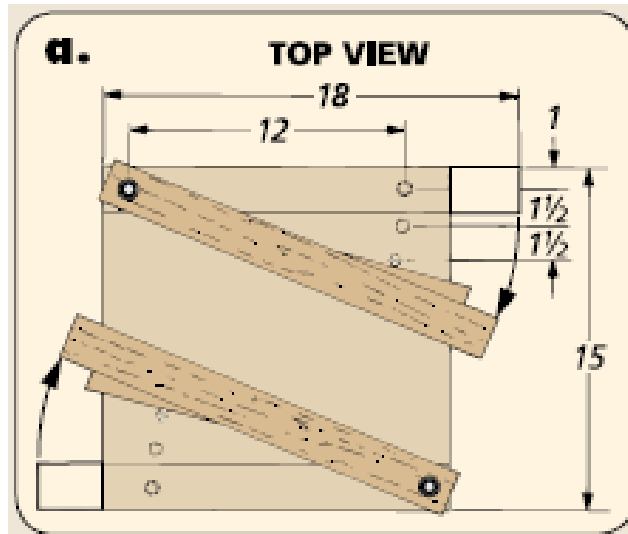

The drawings at right and below show how the jig is constructed. The two arms are bolted into pivot holes near the outside edge of the 3/4" plywood base. An arc of 1/2"-dia. dowel holes radiates from each edge to provide the adjustability. Add a couple of dowels and a pair of wedges and you're in business.

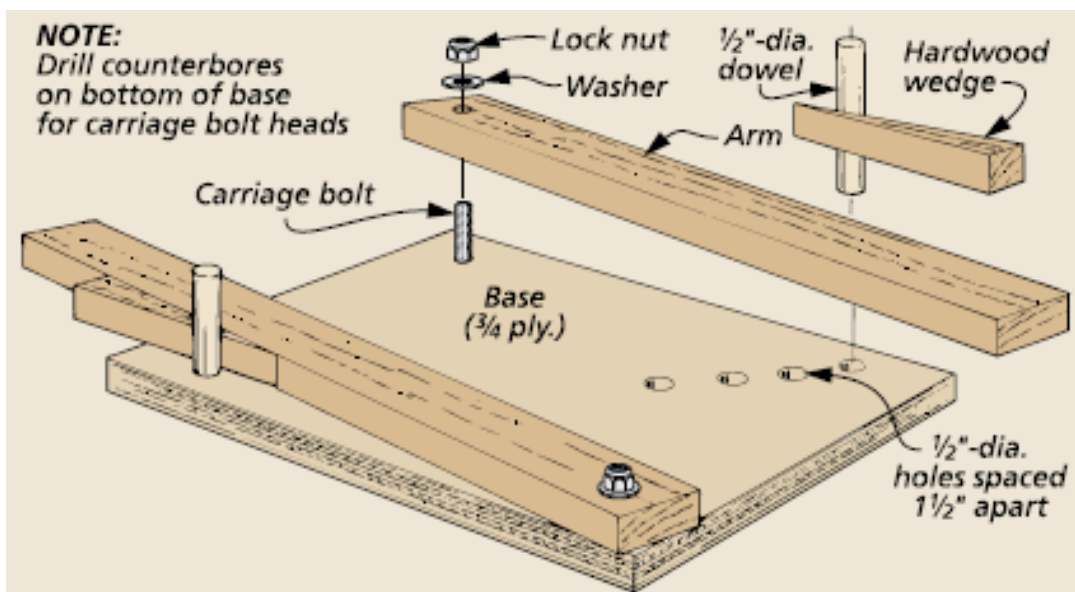

Good woodworking,

Ted Raife

Online Editor, *Woodsmith*